



***Vacuum Packaging***  
***Model VP-IT-0300***  
***Item 47718***  
***Instruction Manual***



*Revised - 10/04/2023*



---

Toll Free: 1-800-465-0234  
Fax: 905-607-0234  
Email: [service@omcan.com](mailto:service@omcan.com)  
[www.omcan.com](http://www.omcan.com)



# ***Table of Contents***

Model VP-IT-0300

---

<b>Section</b>	<b>Page</b>
General Information -----	3 - 4
Safety and Warranty -----	4 - 7
Technical Specifications -----	7
Installation -----	7 - 8
Operation -----	8 - 10
Maintenance and Troubleshooting -----	10 - 13
Parts Breakdown -----	14 - 15
Electrical Schematics -----	16
Notes -----	17 - 18
Warranty Registration -----	19



# General Information

---

Omcan Manufacturing and Distributing Company Inc., Food Machinery of America, Inc. dba Omcan and Omcan Inc. are not responsible for any harm or injury caused due to any person's improper or negligent use of this equipment. The product shall only be operated by someone over the age of 18, of sound mind, and not under the influence of any drugs or alcohol, who has been trained in the correct operation of this machine, and is wearing authorized, proper safety clothing. Any modification to the machine voids any warranty, and may cause harm to individuals using the machine or in the vicinity of the machine while in operation.

## CHECK PACKAGE UPON ARRIVAL

Upon receipt of an Omcan shipment please inspect for external damage. If no damage is evident on the external packaging, open carton to ensure all ordered items are within the box, and there is no concealed damage to the machine. If the package has suffered rough handling, bumps or damage (visible or concealed), please note it on the bill of lading before accepting the delivery and contact Omcan within 24 hours, so we may initiate a claim with the carrier. A detailed report on the extent of the damage caused to the machine must be filled out within three days, from the delivery date shown in the shipping documents. Omcan has no recourse for damaged products that were shipped collect or third party.

**Before operating any equipment, always read and familiarize yourself with all operation and safety instructions.**

Omcan would like to thank you for purchasing this machine. It's of the utmost importance to save these instructions for future reference. Also save the original box and packaging for shipping the equipment if servicing or returning of the machine is required.

---

Omcan Fabrication et distribution Compagnie Limitée et Food Machinery d'Amérique, dba Omcan et Omcan Inc. ne sont pas responsables de tout dommage ou blessure causé du fait que toute personne ait utilisé cet équipement de façon irrégulière. Le produit ne doit être exploité que par quelqu'un de plus de 18 ans, sain d'esprit, et pas sous l'influence d'une drogue ou d'alcool, qui a été formé pour utiliser cette machine correctement, et est vêtu de vêtements de sécurité appropriés. Toute modification de la machine annule toute garantie, et peut causer un préjudice à des personnes utilisant la machine ou des personnes à proximité de la machine pendant son fonctionnement.

## VÉRIFIEZ LE COLIS DÈS RÉCEPTION

Dès réception d'une expédition d'Omcan veuillez inspecter pour dommages externes. Si aucun dommage n'est visible sur l'emballage externe, ouvrez le carton afin de s'assurer que tous les éléments commandés sont dans la boîte, et il n'y a aucun dommage dissimulé à la machine. Si le colis n'a subi aucune mauvaises manipulations, de bosses ou de dommages (visible ou cachée), notez-le sur le bond de livraison avant d'accepter la livraison et contactez Omcan dans les 24 heures qui suivent, pour que nous puissions engager une réclamation auprès du transporteur. Un rapport détaillé sur l'étendue des dommages causés à la machine doit être rempli dans un délai de trois jours, à compter de la date de livraison indiquée dans les documents d'expédition. Omcan n'a aucun droit de recours pour les produits endommagés qui ont été expédiés ou cueilli par un tiers transporteur.

# General Information

---

Avant d'utiliser n'importe quel équipement, toujours lire et vous familiariser avec toutes les opérations et les consignes de sécurité.

Omcan voudrais vous remercier d'avoir choisi cette machine. Il est primordial de conserver ces instructions pour une référence ultérieure. Également conservez la boîte originale et l'emballage pour l'expédition de l'équipement si l'entretien ou le retour de la machine est nécessaire.

Omcan Empresa De Fabricacion Y Distribucion Inc. Y Maquinaria De Alimentos De America, Inc. dba Omcan y Omcan Inc. no son responsables de ningun daño o perjuicio causado por cualquier persona inadecuada o el uso descuidado de este equipo. El producto solo podra ser operado por una persona mayor de 18 años, en su sano juicio y no bajo alguna influencia de droga o alcohol, y que este ha sido entrenado en el correcto funcionamiento de esta máquina, y ésta usando ropa apropiada y autorizada. Cualquier modificación a la máquina anula la garantía y puede causar daños a las personas usando la máquina mientras esta en el funcionamiento.

## REVISE EL PAQUETE A SU LLEGADA

Tras la recepcion de un envio Omcan favor inspeccionar daños externos. Si no hay daños evidentes en el empaque exterior, Habra el carton para asegurarse que todos los articulos solicitados estén dentro de la caja y no encuentre daños ocultos en la máquina. Si el paquete ha sufrido un manejo de poco cuidado, golpes o daños (visible o oculto) por favor anote en la factura antes de aceptar la entrega y contacte Omcan dentro de las 24 horas, de modo que podamos iniciar una reclamación con la compañía. Un informe detallado sobre los daños causados a la máquina debe ser llenado en el plazo de tres días, desde la fecha de entrega que se muestra en los documentos de envío. Omcan no tiene ningun recurso por productos dañados que se enviaron a recoger por terceros.

Antes de utilizar cualquier equipo, siempre lea y familiarizarse con todas las instrucciones de funcionamiento y seguridad.

Omcan le gustaría darle las gracias por la compra de esta máquina. Es de la mayor importancia para salvar estas instrucciones para futuras consultas. Además, guarda la caja original y el embalaje para el envío del equipo si servicio técnico o devolución de la máquina que se requiere.

# Safety and Warranty

---

## WARNINGS

- Pay attention, during machine operation, to the presence of heating elements on the heating bar.
- Use embossed bags to store vacuum packed food, the same type and brand as those supplied; operation of the appliance is not guaranteed with other types and brands of bag.
- Do not place the appliance in water and do not use it if the plug or the cable attached to the plug are wet.
- Every type of intervention on the appliance, including the cleaning operations must be carried out with the

# *Safety and Warranty*

---

plug cable disconnected from the power socket.

- Vacuum packing does not replace other preservation procedures, but can be used alongside them.
- Perishable foods however require refrigeration or freezing to avoid deterioration; vacuum packing lengthens their preservation time and maintains their organoleptic qualities intact.
- The pre-packaged products must be in any case consumed with the expiry date indicated on the packaging.
- A higher vacuum level indicates less presence of oxygen, and therefore the possibility of better preservation.
- Liquids must be refrigerated before being packaged in vacuum pack bags to prevent them leaking or suction in the vacuum chamber.
- Powder products and grains must be covered with a napkin before being vacuum packed to avoid them being sucked into the vacuum chamber, which would obstruct the valve or damage the pump.
- Containers not suitable for vacuum packing preservation can implode due to the effect of the air pressure, causing damage and injury; for freezer preservation, only use the specific tempered glass jars for freezers.
- The vacuum pump and the sealing system are equipped with thermal protection; in the event of overheating, the machine automatically stops and can start working again only after a few minutes of cooling.
- The automatic operating settings were created at the time of manufacture to obtain the best performance of the machine, in terms of safety and reliability. If in particular cases, different performance is required to those pre-set, you need to proceed in manual mode.
- If you don't wait the minimum time required between the connection to the mains and the start of the work cycle, you need to disconnect and re-insert the plug in the socket and wait the minimum time required (15 seconds).
- When using with containers it is recommended to use the appliance in manual mode and to pay close attention to the heating of the sealing bar, to avoid burns.
- If worn, the cable should be replaced by a specialist technician with cable type HAR H05VV-F or however equal to the cable supplied.
- Practice and experience will allow you to obtain the best results from the appliance with every different type of food.
- For its use, pay attention the appliance is on a flat and stable surface.
- To work, the appliance must be connected to a power socket that is always easily accessible during use.
- Acoustic level under 60 dBA.
- Minors must not play with the appliance.
- Cleaning and maintenance of the appliance must not be carried out by unsupervised minors.

## **INFORMATION ON VACUUM PACK PRESERVATION**

### **VACUUM PACKING**

It means removing the air from a container or bag, to preserve the content from harmful effects caused by oxygen, such as oxidation or development of mould and bacteria. All the objects, in contact with the air, are subject to alterations; these alterations are particularly obvious in food. The air and humidity in foodstuffs cause mould and micro-organisms to develop, a loss of flavour and smell and colour alterations. Preservations systems, such as refrigeration, freezing and drying, have the purpose of reducing and preventing such alterations; vacuum packing, thanks to air extraction, considerably lengthens the preservation period of the foodstuff whether fresh or preserved. To make the vacuum time efficient and lasting, the container and the bag

# ***Safety and Warranty***

---

must be correctly sealed.

## **VACUUM PACKING PRESERVATION**

Preservation, especially of foodstuffs, takes place using particular humidity and temperature conditions (for example in the press, refrigerator or freezer); vacuum packing, in addition to the normal preservation methods, considerably lengthens the time these products can be preserved. Vacuum packing preservation also enables flavour, smell, color and nutritional quality of the food to be unchanged.

## **WHY PRESERVE WITH VACUUM PACKING?**

**BECAUSE IT SAVES YOU MONEY:** you can purchase larger quantities of products and in the periods most indicated, keeping them fresh and intact thanks to vacuum packing!

**BECAUSE YOU AVOID WASTE:** the portions of excess food will not go to waste, but can be kept and used later!

**BECAUSE IT SAVES YOU TIME:** you can conveniently cook your meals, preserve them in vacuum packs and use them as you wish, simply by reheating them!

**BECAUSE IT'S MORE HYGIENIC:** vacuum packaging prevents the development of mould, bacteria, micro-organisms and allows you to use the refrigerator and the freezer, avoiding the risk of contamination among foodstuffs and the dispersion of odours!

**BECAUSE IT IS SIMPLE:** with our appliances, everyone can obtain professional quality vacuum packing at home, using the most suitable appliance for your needs, and a complete series of accessories for any type of preservation. Double layer vacuum packing bags, containers in polycarbonate also for oven, microwave and freezer use, and dishwasher safe, universal round and rectangular lids for use with containers, bowls, jars and saucepans for normal household use, small, re-usable lids for glass jars!

## **WARNINGS**

The preservation time of the food greatly depends on the initial conditions of the food. Vacuum packing does not replace other preservation systems. Food that requires appropriate temperature conditions must be kept in the fridge or freezer even if vacuum packed. All pre-packaged products must however be consumed before the expiry date indicated on the packaging. Some types of fruit and vegetables must be peeled or blanched and frozen before vacuum packing.

**RESIDENTIAL USERS:** vendor assumes no liability for parts or labor coverage for component failure or other damages resulting from installation in non-commercial or residential applications. The right is reserved to deny shipment for residential usage; if this occurs, you will be notified as soon as possible.

## **1 YEAR PARTS AND LABOUR BENCH WARRANTY**

Within the warranty period, contact Omcan Inc. at 1-800-465-0234 to schedule a drop off to either an Omcan authorized service depot in the area, or to an Omcan Service warehouse to repair the equipment.

Unauthorized maintenance will void the warranty. Warranty covers electrical and part failures, not improper use.



# Safety and Warranty

Please see <https://omcan.com/disclaimer> for complete info.

## WARNING:

The packaging components are classified as normal solid urban waste and can therefore be disposed of without difficulty.

In any case, for suitable recycling, we suggest disposing of the products separately (differentiated waste) according to the current norms.

**DO NOT DISCARD ANY PACKAGING MATERIALS IN THE ENVIRONMENT!**

# Technical Specifications

<b>Model</b>	<b>VP-IT-0300</b>
<b>Operation Type</b>	Automatic
<b>Power</b>	280 W
<b>Electrical</b>	110-120V / 60Hz / 1
<b>Body</b>	Inox
<b>Pump</b>	One Cylinder Energy Saving
<b>Pump Capacity</b>	-0.9 Bar   40 L/min
<b>Vacuum Seal Bar Width</b>	11.8" / 300mm
<b>Outlet for Canister Attachment</b>	Yes
<b>Vacuometer</b>	Yes
<b>Dimensions</b>	15.4" x 10.8" x 4.9" / 390 x 275 x 125mm
<b>Weight</b>	11.5 lbs. / 5.2 kgs.
<b>Packaging Dimensions</b>	17.3" x 12.6" x 8.3" / 440 x 320 x 210mm
<b>Packaging Weight</b>	14.1 lbs. / 6.4 kgs.
<b>Item Number</b>	47718

# Installation

Install the product on a flat surface that takes into consideration the dimensions of the appliance, levelled, smooth, dry, robust, with the height off the ground of approximately 80 cm and with the useful space necessary

# Installation

---

around it for use and maintenance.

## ENVIRONMENTAL CONDITIONS

Minimum temperature +10° - Maximum temperature + 30°.

Minimum humidity 30% - Maximum humidity 80%.

# Operation

---

## GENERAL USE MANUAL

Having inserted the power supply plug in an adequate socket, wait 15 seconds before starting operations. The appliance is set and guaranteed for use with Reber branded embossed bags, the functionalities of the appliance are not guaranteed in the event of use with different bag types or brands. The vacuum packers with external suction are not suitable for use with products with a high rate of humidity. Any suction of liquids can damage the appliance (pump, electronic data sheet and gaskets of the vacuum chamber); such damage is considered improper use of the machine and is not covered by warranty. The appliance must be kept in a dry place at a temperature of between +10° and + 30°. The bags, especially if the packaging is open, must be kept in a dry place at a temperature of between +10° and + 30°.

## GENERAL SETTINGS

### THE FACTORY SETTINGS INCLUDE

- Electronically set sealing power of 5 time/power units, suitable for the bags supplied, with a thickness of 95/105 micron.
- The sealing power set can be modified using electronic programming using the appliance buttons.
- The appliance is prepared for automatic use of the vacuum/sealing cycle, simply by pressing the start button, without any other use of the buttons.
- Pressing the start button during functioning of the appliance terminates all other operations, stopping both the pump and the sealing bar.
- Electronic programming enables manual functioning passage.
- In manual operating mode, you need to press and release the start button to start the air suction operation and press and release the sealing button to start the sealing operation.
- ATTENTION: if the sealing button is pressed during the sealing operation, the sealing operation is interrupted.
- The appliance is prepared for a standby time of 3 seconds between reaching the vacuum level set and the start of the sealing process (super vacuum function).
- The appliance is prepared for a standby time of 7 seconds at the end of the sealing operation to obtain better sealing quality.
- The appliance is equipped with a welding booster function which increases the welding time by 20% for the first 3 work cycles, beyond 3 cycles, if the appliance is not used for more than 5 minutes, it is advisable to disconnect the appliance from the network to reinitialize the system and use the booster again.

**NOTE: the optimal sealing time can vary based on the type of bag used and the temperature and humidity conditions; you are advised to carry out any tests checking the result. Reduced sealing power will speed up the duration of the cycle and will enable longer working without the thermal protection activating.**

## **IMPORTANT**

In the event of long periods of non-use and/or low temperatures in the work or storage environment of the appliance and the bags, before carrying out the packing procedure, you are advised to keep the pump on for at least a minute and to carry out a vacuum/sealing cycle with a bag, with the cover closed. This operation allows removal of any residual humidity in the sealing zone and establishes the temperature of pump operation.

## **VACUUM PACKING IN BAG**

- Prepare the product by eliminating any roughness that could perforate the bag.
- Insert the product to preserve in a bag suitable for preservation of vacuum packed food, leaving at least 5 cm of free space from the bag opening.
- Lift the cover of the machine and rest the well-laid bag on the sealing bar, taking care to insert the open side of the bag in the vacuum chamber.
- Insert the cable plug in an electricity socket, start the vacuum pump by pressing the switch and exerting light pressure with your hands on the cover to create a first negative pressure in the vacuum chamber; you don't need to press until the end of the operation, but only until the bag starts to stick to the product.
- At the end of the sealing operation, the machine stops. The cover will automatically open.
- Before placing the bag back for preservation, you should check the good quality of the sealing, i.e. the absence of folds or impurities that could enable air passage.

## **VACUUM PACKING IN ROLL SEALING OPERATION WITHOUT VACUUM**

- Lift the cover of the machine and rest the well-laid bag or portion of roll on the sealing bar, taking care NOT to insert the open side of the bag in the vacuum chamber.
- Start the vacuum pump pressing the switch and exert light pressure with your hands on the cover to create a first negative pressure in the vacuum chamber.
- At the end of the sealing operation, the machine stops. Open the cover.
- Cut the sealed roll to the desired length and proceed to vacuum pack as described in the previous chapter.

## **VACUUM PACKING WITH ACCESSORIES AND CONTAINERS (OPTIONAL)**

- This operation requires containers with lids with a vacuum valve and a specific attachment for containers; only use containers suitable for vacuum packing, in plastic or tempered glass).
- Always set the manual operating cycle to avoid damaging the sealing bar. The product to be vacuum packed must always be at room temperature in order not to damage the container and the lid.
- Lift the cover of the machine and identify the air intake.
- Insert the tube of the attachment for containers in the air intake.
- Fill the container leaving at least 3 cm. of free space from the upper edge, and position the lid.
- Slightly unscrew the plug on the lid so the valve is released.

**ATTENTION: the plug must NOT be unscrewed completely, a few turns is enough.**

# Operation

---

- Position the attachment on the plug, covering the valve completely.
- Start the pump on the vacuum until the desired vacuum level is reached.  
**WARNING: Stop vacuum when the red light (if present) is on or when the needle reaches the red level.**
- Once the machine is switched off, remove the attachment for containers from the lid and screw in the plug until the valve is blocked.
- To open the container, slightly unscrew the plug until the valve is released, then move the valve so air enters the container.

## VACUUM PACKING WITH UNIVERSAL LIDS

- Proceed as per vacuum packaging in the container, taking care the edge of the container used sticks perfectly to the universal lid seal.
- In case of prolonged use on the same container, the seal of the lid can have a groove left by the edge of the container; to eliminate any use problems, you must rotate the gasket on the opposite side; then the groove with shortly disappear by itself.
- The seal of the lids can be removed for washing; once dry they must be correctly positioned; Attention! The seal must be washed exclusively by hand with lukewarm water.

## THE VACUUM LEVEL

The vacuum packers come with a vacuum sensor installed on the electronic board that detects reaching the vacuum level obtained on the bag or container, controlling the start of the sealing function (automatic operation). Certain models are also equipped with a device (LED and/or vacuum gauge with hand) that enables the user to check the vacuum level created: switching on the red LED and/or the hand in the red zone of the vacuum gauge indicates the optimal vacuum level has been reached. It is however possible to delay the start of the sealing operation to obtain a greater vacuum level, i.e. not damage the machine in any way. The vacuum level reachable by the machine is conditioned by the equality and shape of the food (or objects) in the bag. Some food (fish, tomatoes, etc.) contain liquids that when compressed leak and can be sucked in causing damage to the machine, and foodstuffs that due to their poor consistency can become crushed or damaged by an excessive vacuum level; for this food, you are advised to check the level of adherence of the bag and proceed to welding before any crushing.

# Maintenance and Troubleshooting

---

## UNDERSTAND AND RESOLVE DOUBTS ON CORRECT USE OF THE APPLIANCES FOR VACUUM PACKING

The appliance is tested at the time of manufacturing with at least 3 vacuum/sealing cycles. If you are having difficulty during use, doubts or problems, you can proceed with some tests to check the efficiency of the product.

# Maintenance and Troubleshooting

---

## AUTO-DIAGNOSIS TESTS

### INTERNAL COMPONENT OPERATION

- With the cover open, press the start button and close the air press with a finger.
- If the hand on the vacuum gauge reaches red (and/or the red led switches on) and sealing automatically starts, internal operation is correct.
- If the hand on the vacuum gauge reaches red (and/or the red led switches on) but sealing does not automatically start, you need to set the machine for automatic operation and try again.
- If the hand on the vacuum gauge does not reach red (and/or the red light does not switch on) the vacuum pump is damaged or there is an air leak in the internal tubes circuit - contact a support centre for repair.

### OPERATION OF THE COVER AND GASKETS ON THE VACUUM CHAMBER

- Close the cover on the machine (without inserting the bag), press the start button and exert light pressure on the cover to start the automatic cycle.
- If the hand on the vacuum gauge reaches red (and/or the red led switches on) and sealing automatically starts, machine operation is correct.
- If the hand on the vacuum gauge reaches red (and/or the red led switches on) but sealing does not automatically start, you need to set the machine for automatic operation and try again.
- If the hand on the vacuum gauge does not reach red (and/or the red light does not switch on), you need to check the chamber gaskets of the vacuum (clean the gaskets or replace them) and try again.

### BAG INSERTION TEST

- Lift the cover.
- Position the open end of the empty bag in the chamber of the vacuum, between the gaskets in the vacuum chamber.
- Lower the cover, press the start button and exert light pressure on the cover to start the automatic cycle.
- If the hand on the vacuum gauge reaches red (and/or the red led switches on) and sealing automatically starts, machine operation is correct.
- If the hand on the vacuum gauge reaches red (and/or the red led switches on) but sealing does not automatically start, you need to set the machine for automatic operation and try again.

Using these tests, you can check machine operation and you get correct insertion of the bag in the vacuum chamber. Correct packaging is only obtained if enough free space is left between the product and the machine (approx. 5 cm. are usually enough) provided the bag can be inserted well laid between the gaskets of the vacuum chamber, without creating folds that could create air leaks, reducing the vacuum level and the quality of sealing.

### THE MACHINE DOES NOT START

- Check you have correctly inserted the plug in the electricity socket and the press is powered.

### THE BAG IS NOT WELL SEALED/AIR IS ENTERING THE BAG

- During the winter period, and in the presence of extreme temperature changes, the sealing bar can fill with humidity. On first start-up of the cold machine you should execute a completed vacuum/sealing cycle with the cover closed (also without a bag) to reset the machine and stabilise the temperature and humidity conditions. To avoid problems also on first use, the appliance must be kept in a dry place at a temperature

# Maintenance and Troubleshooting

---

of between +10° and + 30°.

- The bags are composed of an outer layer in nylon to protect against air intake; the nylon tends to absorb humidity especially in the presence of temperature changes; the humidity absorbed prevents correct sealing: to solve the problem, the bags must be kept in a dry place at temperature between +10° and + 30°.
- The humidity absorbed by the outer layer of the bag can be eliminated by sealing the bag twice.
- Check you have left sufficient free space between the product to pack and the opening of the bag; a limited space creates folds and bends to prevent correct sealing and limits the vacuum level reachable.
- Check you have cleaned the opening of the bag near the sealing point; any impurities deriving from passage of the product to package, prevents correct sealing.
- Check you have removed all possible roughness that could perforate the bag; the machines create a high vacuum level with resulting adhesion of the bag to the product, any point or roughness can create micro-pores in the bag to let air in.
- Humid products can cause liquid to rise towards the opening of the bag, damaging sealing; check you have dried the products to package or use a double bag; insert the product in a first bag, fold the mould of the bag a few times and place it in a second bag with the opening folded of the first turned towards the bottom of the second. You can execute the vacuum function and any residual liquids will stay in the first bag without passing into the second, as such obtaining efficient sealing.
- When you use rolls, the first sealing must be carried out by positioning the mouth on the roll on the sealing bar and not in the vacuum chamber; the machine seals correctly only if the cover exerts correct pressure on the sealing bar. Anticipating sealing before having a sufficient vacuum level can create channels with air passage and make sealing inefficient. You are advised to carry out a complete automatic vacuum/sealing cycle.
- Sealing only function: position the opening of the bag on the sealing bar and not in the vacuum chamber; the machine seals correctly only if the cover exerts correct pressure on the sealing bar. Anticipating sealing before having a sufficient vacuum level can create channels with air passage and make sealing inefficient. You are advised to carry out a complete automatic vacuum/sealing cycle.
- If air enters the bag during the sealing phase and after a correct vacuum/sealing cycle, you need to replace the bag which is probably damaged.

## **THE MACHINE DOES NOT CREATE A VACUUM IN THE BAG**

- Check you have correctly positioned the opening of the bag between the seals of the vacuum chamber.
- Proceed with auto-diagnosis tests to ensure the machine is working correctly.
- The machine works correctly with original, embossed type bags. Different bags may not work adequately; check you have used the correct bags.
- During the summer period (when temperatures are higher) or in the event of prolonged use, the residual heat on the sealing bar can create pre-sealing of the bag to prevent the machine from correctly sucking: decrease the sealing power using the electronic programming to decrease the sealing time, wait a few minutes for the sealing bar to cool and continue to work with a lower sealing power.
- Check the seals on the vacuum chamber; in the event of slight liquid suction the seals can harden and get damaged; in this case you need to change the seals.

## **THE MACHINE DOES NOT AUTOMATICALLY SEAL**

- Proceed with auto-diagnosis tests to ensure the machine is working correctly.
- Start a vacuum cycle and manually seal to check the sealing bar is working properly.
- Check the electronic settings as described in the paragraph "Reset the factory parameters" or adjust the

# ***Maintenance and Troubleshooting***

---

setting on automatic operation as described in the paragraph "Pass from manual to automatic operation".

- Check you have left sufficient free space between the product to pack and the opening of the bag; a limited space creates folds and bends on the opening of the bag that limits the vacuum level reachable and prevent the vacuum sensor from starting automatic sealing.

## **THE MACHINE DOES NOT REACH A CONVENIENT VACUUM LEVEL**

- Check you have correctly positioned the opening of the bag between the seals of the vacuum chamber.
- Proceed with auto-diagnosis tests to ensure the machine is working correctly.
- The machine works correctly with original, embossed type bags. Different bags may not work adequately; check you have used the correct bags.
- Check you have removed all possible roughness that could perforate the bag; the machines create a high vacuum level with resulting adhesion of the bag to the product, any point or roughness can create micro-pores in the bag to let air in.
- Check you have left sufficient free space between the product to pack and the opening of the bag; a limited space creates folds and bends on the opening of the bag that limits the vacuum level reachable.
- Check the seals on the vacuum chamber; in the event of slight liquid suction the seals can harden and get damaged; in this case you need to change the seals.

**Note: hydraulic oil to be used is Omcan item 15713.**

# Parts Breakdown

Model VP-IT-0300 47718

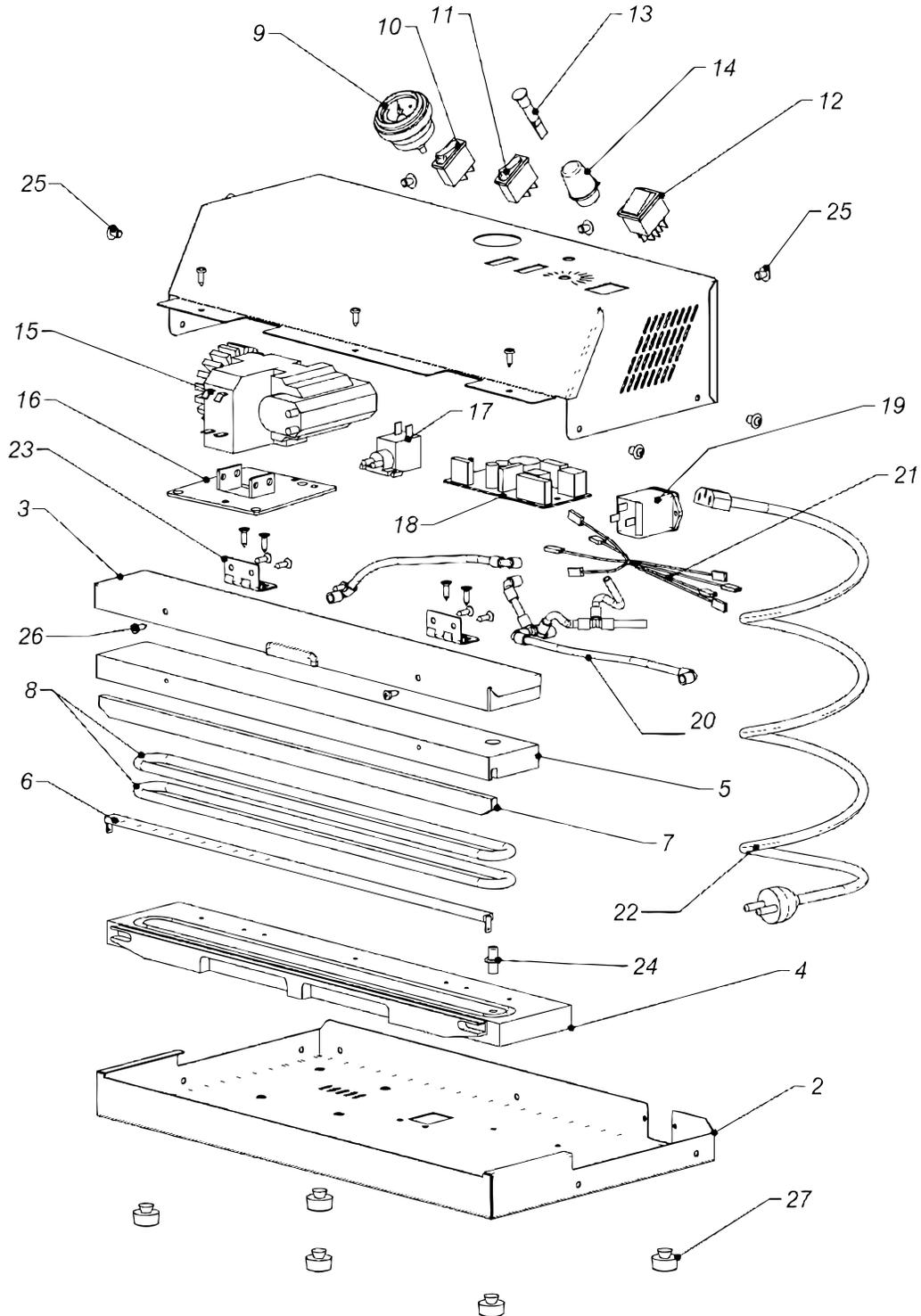



# Parts Breakdown

## Model VP-IT-0300 47718

Item No.	Description	Position	Item No.	Description	Position	Item No.	Description	Position
AO021	Body for 47718	1	AO028	Seal Switch for 47718	11	AO038	Green Wiring for 47718	21
AO022	Base for 47718	2	AO029	Welding LED for 47718	13	AO039	Black Wiring for 47718	21
AO023	Cover for 47718	3	AO030	Green LED for 47718	14	AO040	Cable/Plug for 47718	22
AO024	Lower Vacuum Chamber for 47718	4	AO031	Vacuum Pump for 47718	15	AO041	Hinges with Screws for 47718	23
AO025	Upper Vacuum Chamber for 47718	5	AO032	Pump Base for 47718	16	AO042	Vacuum Socket for 47718	24
41618	Sealing Bar Complete for 47718	6	AO033	Solenoid Valve for 47718	17	AO043	Screw Rivet for 47718	25
72249	Top Bar for 47718	7	AO034	Electronic Board for 47718	18	AO044	Cover Screws for 47718	26
72246	Gasket for 47718	8	AO035	Filter Socket with Fuse for 47718	19	AO045	Base Feet for 47718	27
AO026	Vacuum Gauge for 47718	9	AO036	"N" Series Hose Set for 47718	20			
AO027	Start/Stop Switch for 47718	10	AO037	"NF" Series External Filter for 47718	20			

# Electrical Schematics

## Model VP-IT-0300 47718

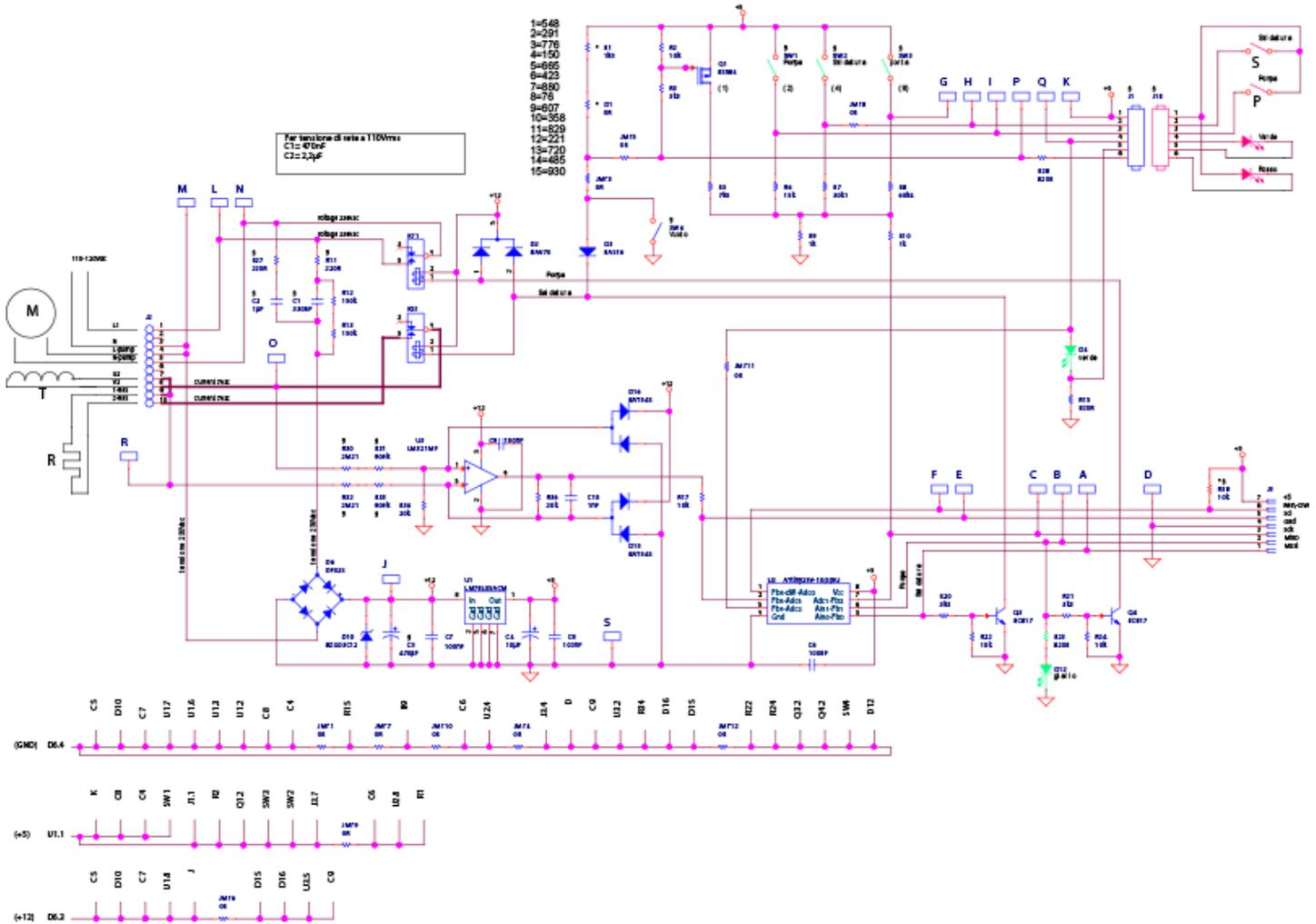

**NEMA**  
5 - 15P  
125VAC / 15 AMP







# Warranty Registration

Thank you for purchasing an Omcan product. To register your warranty for this product, complete the information below, tear off the card at the perforation and then send to the address specified below. You can also register online by visiting:

Merci d'avoir acheté un produit Omcan. Pour enregistrer votre garantie pour ce produit, complétez les informations ci-dessous, détachez la carte au niveau de la perforation, puis l'envoyer à l'adresse spécifiée ci-dessous. Vous pouvez également vous inscrire en ligne en visitant:

Gracias por comprar un producto Omcan usted. Para registrar su garantía para este producto, complete la información a continuación, cortar la tarjeta en la perforación y luego enviarlo a la dirección indicada a continuación. También puede registrarse en línea en:

<https://omcan.com/warranty-registration/>

For mailing in Canada

Pour postale au Canada

Por correo en Canadá

**OMCAN**

PRODUCT WARRANTY REGISTRATION

3115 Pepper Mill Court,

Mississauga, Ontario

Canada, L5L 4X5

For mailing in the US

Pour diffusion aux États-Unis

Por correo en los EE.UU.

**OMCAN**

PRODUCT WARRANTY REGISTRATION

4450 Witmer Industrial Estates, Unit 4,

Niagara Falls, New York

USA, 14305

*or email to: [service@omcan.com](mailto:service@omcan.com)*



Purchaser's Information

Name: \_\_\_\_\_

Address: \_\_\_\_\_

City: \_\_\_\_\_ Province or State: \_\_\_\_\_ Postal or Zip: \_\_\_\_\_

Country: \_\_\_\_\_

Dealer from which Purchased: \_\_\_\_\_

Dealer City: \_\_\_\_\_ Dealer Province or State: \_\_\_\_\_

Invoice: \_\_\_\_\_

Model Name: \_\_\_\_\_ Model Number: \_\_\_\_\_

Machine Description: \_\_\_\_\_

Date of Purchase (MM/DD/YYYY): \_\_\_\_\_

Would you like to extend the warranty?  Yes  No

Company Name: \_\_\_\_\_

Telephone: \_\_\_\_\_

Email Address: \_\_\_\_\_

Type of Company:

Restaurant  Bakery  Deli

Butcher  Supermarket  Caterer

Institution (*specify*): \_\_\_\_\_

Other (*specify*): \_\_\_\_\_

Serial Number: \_\_\_\_\_

Date of Installation (MM/DD/YYYY): \_\_\_\_\_

**Thank you for choosing Omcan | Merci d'avoir choisi Omcan | Gracias por elegir Omcan**



Since 1951 Omcan has grown to become a leading distributor of equipment and supplies to the North American food service industry. Our success over these many years can be attributed to our commitment to strengthen and develop new and existing relationships with our valued customers and manufacturers. Today with partners in North America, Europe, Asia and South America, we continually work to improve and grow the company. We strive to offer customers exceptional value through our qualified local sales and service representatives who provide convenient access to over 6,500 globally sourced products.

---

Depuis 1951 Omcan a grandi pour devenir un des “leaders” de la distribution des équipements et matériel pour l’industrie des services alimentaires en Amérique du Nord. Notre succès au cours de ces nombreuses années peut être attribué à notre engagement à renforcer et à développer de nouvelles et existantes relations avec nos clients et les fabricants de valeur. Aujourd’hui avec des partenaires en Amérique du Nord, Europe, Asie et Amérique du Sud, nous travaillons continuellement à améliorer et développer l’entreprise. Nous nous efforçons d’offrir à nos clients une valeur exceptionnelle grâce à nos ventes locales qualifiées et des représentants de service qui offrent un accès facile à plus de 6500 produits provenant du monde entier.

---

Desde 1951 Omcan ha crecido hasta convertirse en un líder en la distribución de equipos y suministros de alimentos en América del Norte industria de servicios. Nuestro éxito en estos años se puede atribuir a nuestro compromiso de fortalecer y desarrollar nuevas relaciones existentes con nuestros valiosos clientes y fabricantes. Hoy con socios de América del Norte, Europa, Asia y América del Sur, que trabajan continuamente para mejorar y crecer la empresa. Nos esforzamos por ofrecer a nuestros clientes valor excepcional a través de nuestro local de ventas y representantes de los servicios que proporcionan un fácil acceso a más de 6,500 productos con origen a nivel mundial.

